

Frontplattenausschnitt (Rückseite)
Panel cut out (rear side)

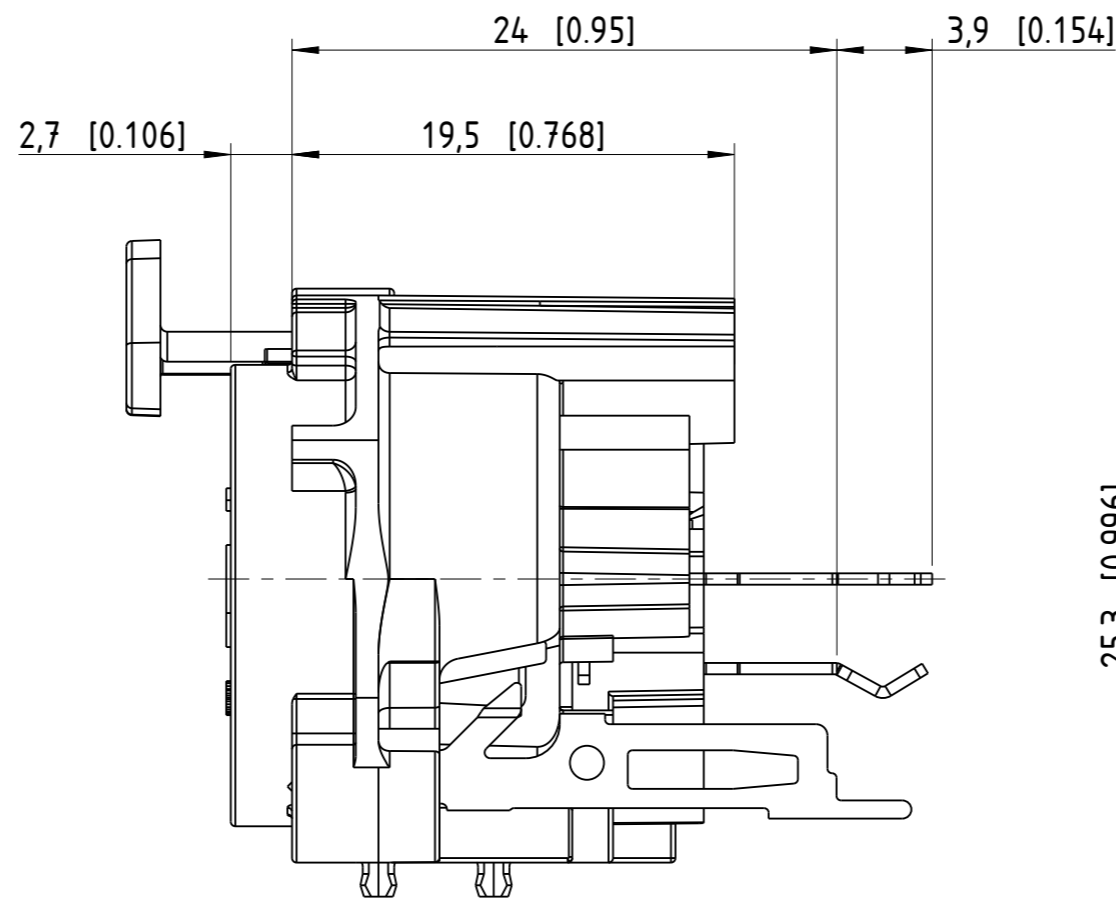

Print-Bohrplan (Bestückungsseite)
PCB-Layout (component side)

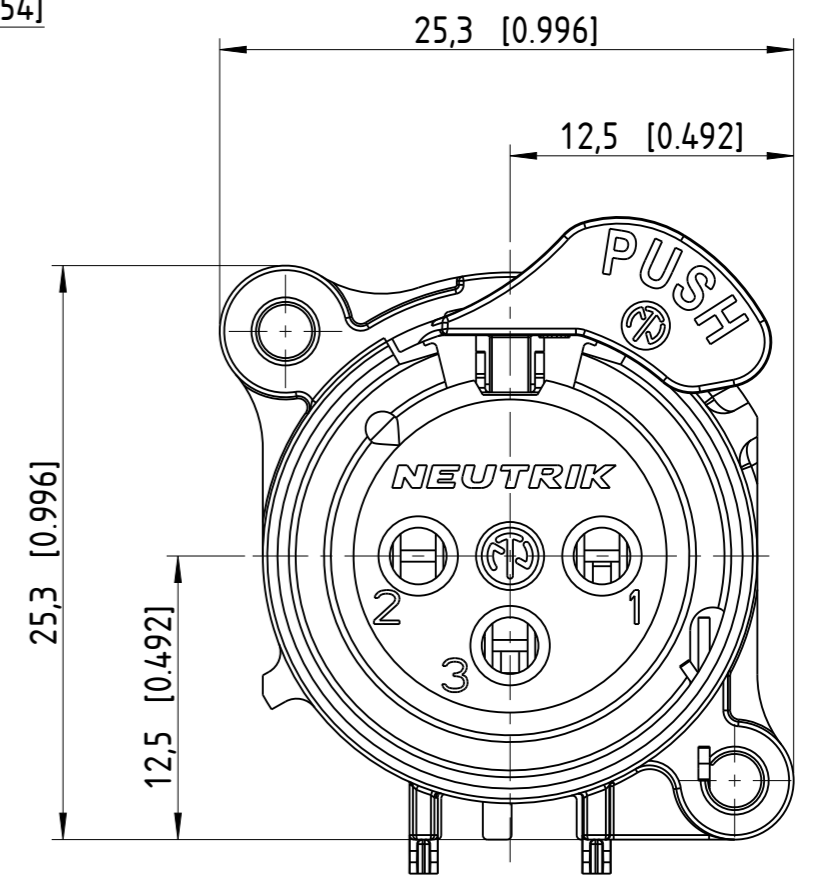

min. Einbauabstand
min assembling distance

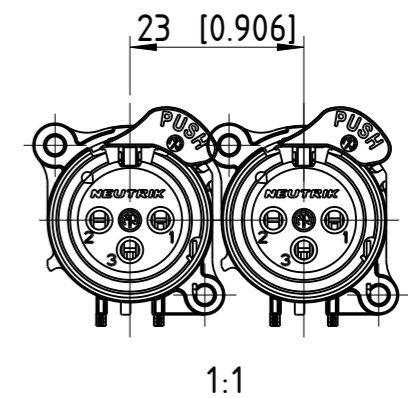
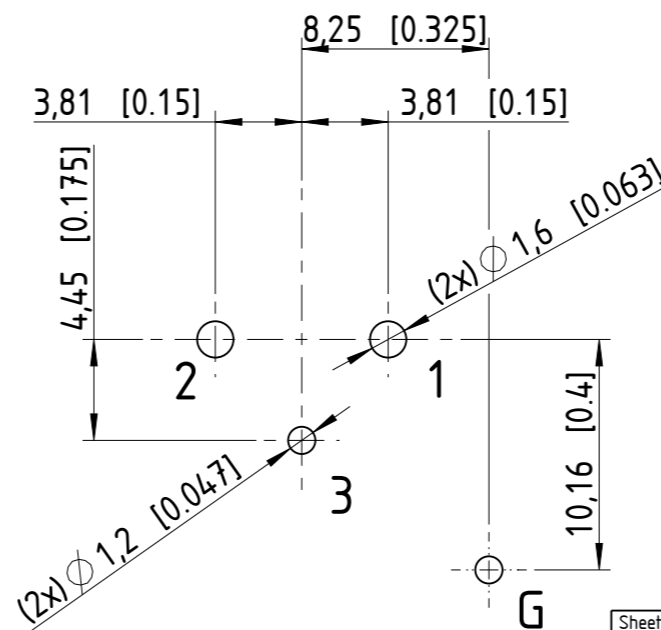
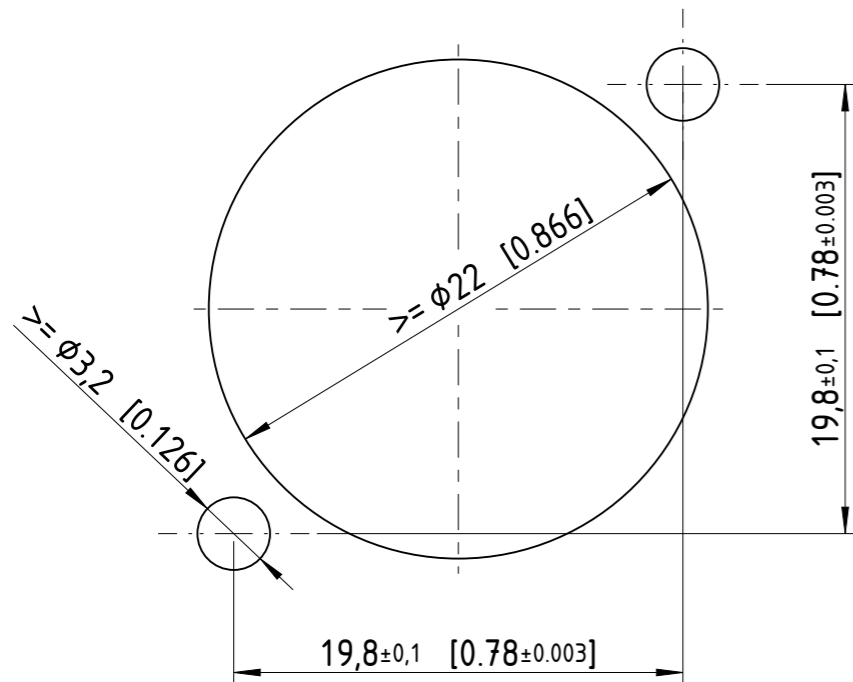

| | | | | | |
|---------------------|----------------|-----------------|-------------------------------|------------------------------------|------------------------|
| Sheet Number 1/1 | Projection | Scale 3:1 | Format A3 | General Tolerancing ISO 2768 mK | |
| Description | | | Created on/by | 04.07.2023 | Schmiel T. |
| NC3FAV2-AE | | | Approved on/by | 05.07.2023 | Schuster R. |
| | | | Article ID NC3FAV2-DA E | Model ID 30010763 | Drawing ID 20004439 |
| Status Released | Revision - | ECN Number - | Neutrik Group | | |